

*Dunsley*



Wood and Multi-fuel Stoves



CE APPROVED  
HETAS APPROVED



Highlander 5

## Dunsley Highlander-3

The Highlander-3 has been designed to give you cleaner burn and superb efficiency.

Its slim appearance and air wash gives it an appearance to be desired. The air wash and primary air controls are designed to be precisely controlled, to allow maximum efficiency to be obtained and control outputs to your requirements.

The Highlander-3 is also fitted as standard with a superb shaker grate. This enables logs or any other solid fuel to be burnt at maximum efficiency and is very easy and clean to operate.

A non shaker grate model is also available, with the design advantages of the Highlander-3 but without the shaker mechanism. This gives you a very good stove at a reduced price. You will of course have to de-ash as required with the hooked poker provided.

The Highlander-3 is available with matching canopy, on request. This can be removed or replaced at any time.

The Highlander-3 has interchangeable top or rear flue outlets fitted as standard, to take 125mm flue pipe.

The Highlander-3 has been designed with one door to open for re-fuelling and ash removal, therefore no safety precautions are necessary to prevent overfiring of fuel when removing ash from below the grate.

The Highlander-3 will take logs up to 200mm (8") long.

The air wash system has been designed to keep the glass clean to give a full view of the superb flame

pattern, created as the flames rise to meet the incoming air, thus causing secondary combustion to take place.



Highlander 3 >

### HEAT OUTPUTS IN kW

MIN. 1 MAX. 3.3

SEE PAGE 12 FOR MEASUREMENTS AND ACCESSORIES

## Dunsley Highlander-5

### HETAS APPROVED

The Highlander-5 has been developed to increase the choice of the Householder, using the superb burning technology from the Highlander-7. The same metallic black finish; airwash system; and matching shaker grate system, only slightly smaller but can still take large logs up to 280mm long. Solid brass handles as standard, with black or polished cast handles available on request. The Highlander-5 comes in either SL-Short Legs or HL-High Legs variants both can be fitted with a canopy.

The Highlander-5 is different from the Highlander-7 as follows - the overall size is smaller, this has enabled the design of the door to be altered, so that on the Highlander-5 there is only one door to open for re-fuelling and removing ashes. This also means that the safety precaution to prevent overfiring is automatically provided for.

### HOW IT WORKS

The Highlander-5 has two combustion controls exactly as the Highlander-7. The most suitable setting will quickly be found moving the slide slowly to find the most suitable position. Using the correct rate of burning efficiencies of up to 82% burning wood logs and 76% burning ancit can be obtained.

**The Highlander-5 is also available with Stainless Steel 2kW Boiler.**

### HEAT OUTPUTS IN kW

WITHOUT DOMESTIC BOILER  
MIN. 1.3 MAX. 5

WITH DOMESTIC BOILER  
To room up to 3kW  
To water up to 2kW  
Outputs will vary with the type of fuel used and the burning rate.

SEE PAGE 12 FOR MEASUREMENTS AND ACCESSORIES



Highlander 5HL (High Legs) >





Highlander 7HL

## Dunsley Enviro-burn - 5

**CLEAN & CLEAR:** Enviro burn clean combustion with tertiary and airwash air supply means a clear view of the flames.

**HETAS APPROVED:** The Highlander Enviro-burn-5 is a free standing stove approved to burn wood logs in a smoke controlled area. The appliance is constructed from 4 and 10mm steel and cast iron. It incorporates both a rear and top flue outlet. The firebox is lined at the sides back and top with extra high density Refractory Boards" and comes with a black metallic finish. You have a choice of brass, black or polished steel handles. A canopy can be supplied on request.

The Highlander Enviro-burn-5 has only one door to open for re-fuelling and removing ashes. This also means that the safety precaution to prevent overfiring is automatically provided for.

## Dunsley Highlander-7

### HETAS APPROVED

Meets the requirements of the relevant British Standards for the whole of the UK. Also meets the requirements of the Scotland Building Regulations 1999 Part F.

The Highlander-7 has been developed using the best burning technology to give you a stove with cleaner burn and high efficiency.

An automatic door safety device is fitted which prevents the bottom door from opening before the top door is open. This prevents serious overfiring when removing the ashes from below the grate.

The Air Wash System has been designed to keep the glass clean to give a full view of the superb flame pattern, created as the flames rise to meet the incoming air, this causes secondary combustion to take place, resulting in cleaner burn with dancing flames.

The Highlander has also a superb shaker grate mechanism, which allows you to set the grate for efficient woodburning (large logs up to 360mm long) or ancit smokeless fuel.

Handles are Finished in heat resistant metallic black stove enamel paint, and fitted with solid brass handles, black or polished cast handles are available on request.

**HOW IT WORKS:** The Highlander Enviro-burn-5 has two combustion controls. The most ideal setting will quickly be found moving the slide slowly to find your most suitable position. Using the correct rate of burning efficiencies of up to 78.9% burning wood logs can be achieved.

The Enviro-burn-5 is now available in high leg (5HL) and short leg (5SL) versions, for dimension please seepage 12.



### HEAT OUTPUTS IN kW

Nominal Heat Output of 4.9kW  
Efficiency 78.9%

**SEE PAGE 12 FOR MEASUREMENTS AND ACCESSORIES**

*“Enviro-burn-5”*

burning wood in smoke controlled areas



The Highlander-7 comes in either SL-Short Legs or HL-High Legs variants.

The Highlander-3, -5, -7 and -8 have interchangeable top or rear flue outlets fitted as standard.

### HOW IT WORKS

The highlander has two controls. The one above the main door controls the amount of air required for the air wash system.

By sliding the control left to close, right to open the air inlet holes, which then pre-heats the air before directing it down over the inside of the ceramic glass. This keeps the products of combustion away from the glass and also creates secondary combustion to increase efficiency and reduce smoke emissions from the flue.



**Highlander 7SL (Short Legs) >**

### HEAT OUTPUTS IN kW

WITHOUT DOMESTIC BOILER  
MIN. 1.75 to 6kW nominal  
output MAX. 7

WITH DOMESTIC BOILER  
To room up to 3kW  
To water up to 3kW  
Outputs will vary with the type of fuel used and the burning rate.

**SEE PAGE 12 FOR MEASUREMENTS AND ACCESSORIES**



Highlander 8 Solo

## Dunsley Highlander-8

Now available as a Highlander-8-Solo the new single door model and as the standard two door options. The Highlander-8 has a wide door opening and large fire bed capacity, enables you to load the fire box with good sized logs of up to 460mm or 18" length.

The highlander-8 has an air wash system designed to keep the glass clean by diverting a warm flow of air directly over the surface of the glass. Each door has its own primary air controls. This controls the amount of fuel being burnt and can also be closed down for overnight burning of fossil fuels.

With a heat output of 7 - 8 kW maximum the Highlander-8 will heat a medium to large room.

The grate mechanism can be adjusted for burning wood or other solid fuels including: peat, coal and coal briquettes.

Using the correct rate of burning efficiencies of up to 78% on wood logs and 75% on ancit can be obtained.



^  
Highlander-8 Solo  
(Single door model)



^  
Highlander-8  
(Double door model)

### HEAT OUTPUTS IN kW

WITHOUT DOMESTIC BOILER  
MIN. 2 MAX. 7.5



WITH DOMESTIC BOILER  
To room up to 5kW  
To water up to 4kW

Outputs will vary with the type of fuel used and the burning rate. See page 8 for more details on central heating models.

**SEE PAGE 12 FOR MEASUREMENTS AND ACCESSORIES**

## Dunsley Highlander-10

New for this season the Highlander-10-Solo the single door version of the standard two door options. The Highlander 10 is a wide version of the 8 model. With the same burning control system and nearly 100mm wider than the 8 this makes it more suitable for larger rooms, and a fuel box area to take logs up to 550mm long.

The flue spigot can be changed from top to rear on site if required.

Using the correct rate of burning efficiencies of up to 78% on wood logs and 75% on ancit can be obtained.

Both the Highlander 8 & 10 are available with black, brass or polished steel door handle.



^  
Highlander-10 Solo  
(Non-Boiler model  
Single door model)



^  
Highlander-10  
(Non-Boiler model  
Double door model)

### HEAT OUTPUTS IN kW

WITHOUT DOMESTIC BOILER  
MIN. 2 MAX. 9 to 10kW

WITH DOMESTIC BOILER  
To room up to 6kW  
To water up to 4.5kW

Outputs will vary with the type of fuel used and the burning rate. See page 8 for more details on central heating models.

**SEE PAGE 12 FOR MEASUREMENTS AND ACCESSORIES**



^  
New detailing and handle on the Solo single door models



Highlander 10



# Dunsley Highlander - 8 & 10 with Central Heating Boiler

The Highlander-8 and 10 are fitted with a fully integral boiler for central heating and domestic hot water as well as providing heat into the room.

The Highlander-8 and 10 have a built in thermostat which automatically monitors the central heating temperature and controls the incoming air to regulate how the fire burns to meet the central heating requirements.

The Highlander-8 and 10 can be supplied with an external air intake pipe which is fitted to the air box underneath the stove, this allows combustion air to be taken from outside the building. If this method is used no extra air vents into the room is required. Both '8' and '10' have multifuel grate bars as standard.

Both stoves can be supplied with brass, black or polished steel knobs, and finished in black metallic matt paint.

**Please note** - the Highlander central heating models are only available with top flue connection and have straight legs.

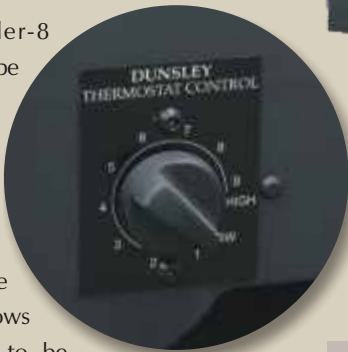

The Highlander 8 and 10 central heating models are available as the New - Solo single door or double doors model options

Highlander 10



The New Highlander 8-Solo single door option burning smokeless fuel >

Multi fuel stove with C/H boiler - heat outputs under test conditions

	HIGHLANDER-8	HIGHLANDER-10
<b>Four hour refueling</b>	<b>Burning Ancit</b> the efficiency is 71.3%	<b>Burning Ancit</b> the efficiency is 73.8%
Output to Water	7.7kW (26,272 BTU's)	10.5kW (35,826 BTU's)
Output to Room	3.8kW (12,965 BTU's)	3.8kW (12,965 BTU's)
<b>TOTAL</b>	<b>11.5kW (39,237 BTU's)</b>	<b>14.3kW (48,791 BTU's)</b>
<b>one hour refueling</b>	<b>Burning Logs</b> the efficiency is 72.8%	<b>Burning Logs</b> the efficiency is 74.2%
Output to Water	5.8kW (19,789 BTU's)	8.2kW (27,978 BTU's)
Output to Room	3.9kW (13,306 BTU's)	5.2kW (17,742 BTU's)
<b>TOTAL</b>	<b>9.7kW (33,095 BTU's)</b>	<b>13.4kW (45,720 BTU's)</b>

Higher outputs can be achieved by adjusting the boiler thermostat.  
SEE PAGE 12 FOR MEASUREMENTS AND ACCESSORIES

## Highlander 8 Double Fronted Stove

The Highlander 8 double fronted stove is ideal for homes, pubs or hotels that have, or wish to create a central chimney room setting as a focal point.

With a heat output of 7 - 8 kW maximum the Highlander-8 will heat a medium to large room.

The grate mechanism can be adjusted for burning wood or other solid fuels including: peat, coal and coal briquettes.

**Please note** - the Highlander 8 Double fronted is only available with top flue connection.



< Highlander 8 Double Fronted



< The New Highlander 8-Solo single door option burning smokeless fuel

### HEAT OUTPUTS IN kW

MIN. 2 MAX. 7.5

Outputs will vary with the type of fuel used and the burning rate.

SEE PAGE 14 FOR MEASUREMENTS AND ACCESSORIES



Highlander 8 Log Store

# Dunsley Highlander-16 Central Heating

**CLEAN, CLEAR & HIGH OUTPUTS:** With high heat outputs of up to 16.9kW on 4 hour refueling. You would think that efficiency was not a consideration for the engineers of Dunsley but built to the highest standards this is quality stove designed for superb cleaner burning and clean combustion including an airwash air supply giving a clear view of the dancing flames.

**HETAS APPROVED:** The Highlander-16 comes with a black metallic finish. You have a choice of brass, black or polished steel handles. A canopy can be supplied on request.

**HOW IT WORKS:** The Highlander-16 has two combustion controls. The most ideal setting will quickly be found by adjusting the thermostat to find your most suitable position. Using the correct rate of burning efficiencies of up to 73.9% burning ancit can be achieved.



## The New Highlander 16-Solo >

### HEAT OUTPUTS IN kW

<b>Four hour refueling</b>	<b>Burning Ancit</b> the efficiency is 73.9%
Output to Water	12.4kW (42,308 BTU's)
Output to Room	4.5kW (15,354 BTU's)
<b>TOTAL</b>	<b>16.9kW (57,662 BTU's)</b>
<b>one hour refueling</b>	<b>Burning Logs</b> the efficiency is 73.1%
Output to Water	8.5kW (29,002 BTU's)
Output to Room	7.1kW (24,225 BTU's)
<b>TOTAL</b>	<b>15.6kW (53,227 BTU's)</b>



Higher outputs can be achieved by adjusting the boiler thermostat.  
SEE PAGE 14 FOR MEASUREMENTS AND ACCESSORIES

# Dunsley Highlander Log Store Range

The Highlander Multi-Fuel range of stoves is now complemented by a Log Store model which has all the features of our standard range of stoves.

The Log Store has top or rear flue outlets which can be changed on site. Leveling adjusting bolts are fitted as standard at each corner to assist on uneven floors.

The Log Store range is ideal for homes where a chimney is built, to make a feature against a wall or fitting into an Inglenook type fireplace opening.

The log store area is large enough on each stove to store logs for a cold Winter's night, with the radiant heat and flickering flames reminding you of warm rays of sunshine.



## Highlander 5 > Log Store



< Highlander 8 Log Store with double doors or new highlander-8-Solo single door version

< Highlander 10-Solo Log Store with single door or standard double doors



## Highlander 7 > Log Store

SEE PAGE 14 FOR MEASUREMENTS AND ACCESSORIES



Highlander 16

# Dimensions and flue sizes

## Highlander 3, 5 and 7

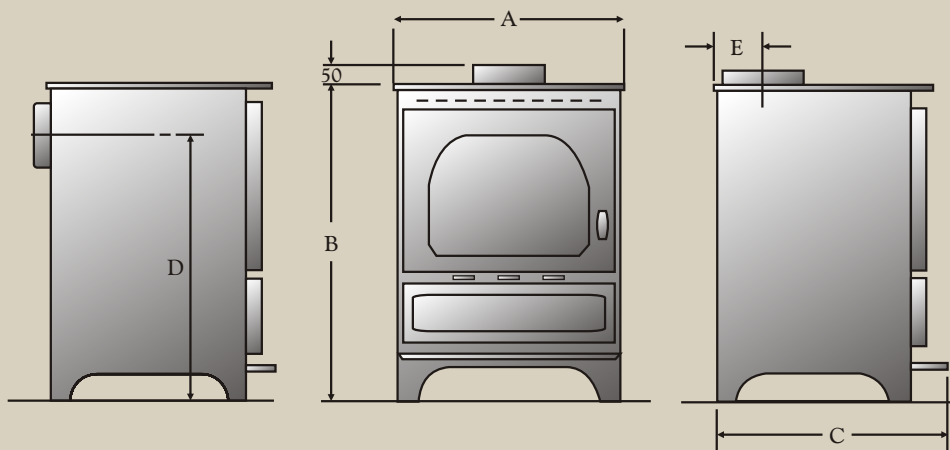

HIGHLANDER MODEL & DIMENSIONS					
	3	5SL	5HL	7SL	7HL
A	350	425	425	520	520
B	560	560	630	650	720
C	385	385	385	385	385
D	445	445	515	536	606
E	105	105	105	118	118

measurements in millimetres

Note - the 3 & 5 take 125mm flue and the 7 takes 150mm flue

## Dunsley Enviro-burn - 5

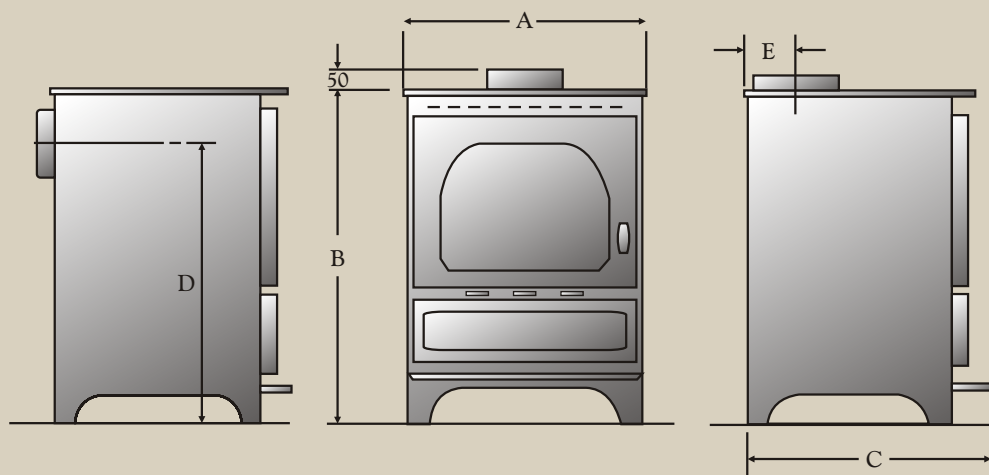

MODEL DIMENSIONS		
	5HL	5SL
A	425	425
B	630	560
C	385	385
D	515	445
E	105	105

measurements in millimetres

Note - the Enviroburn-5 takes 125mm flue

## Dunsley Highlander 8 & 10

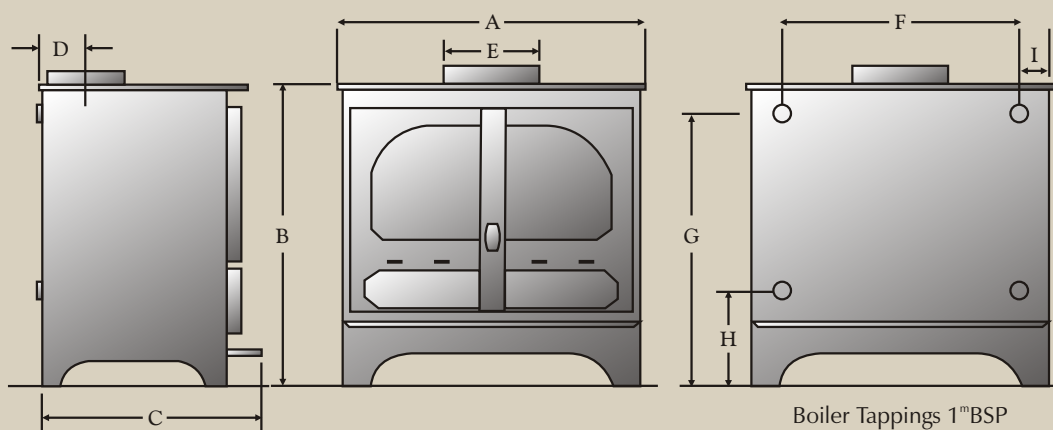

MODEL DIMENSIONS				
	8	10	8CH	10CH
A	605	690	690	690
B	630	630	630	645
C	385	385	385	485
D	118	118	515	118
E	160	160	160	160
F			400	485
G			600	600
H			340	250
I			85	100

measurements in millimetres

Note - the 8 and 10 take 150mm flue

### BEFORE YOU DECIDE

Of course, we would like you to choose a Dunsley 'Highlander' stove - before you do, may we suggest you check the following advantages

- Fitted with cast iron multi fuel riddling grate as standard
- Chrome iron grate bars are available, as an optional extra, for those who wish to burn Petroleum coke and Welsh Dry steam coal
- Very efficient air wash, which also improves fuel efficiency
- Automatic door safety device
- Large ash capacity below grate bars
- 3 Year guarantee
- The Highlander stoves can also be used in smoke controlled areas when burning authorised smokeless fuels

Dunsley Yorkshire - the smokeless stove  
please visit the website or ask for a brochure



# Dunsley Highlander Log Store Range Plus The Highlander 8 Double Fronted Stove

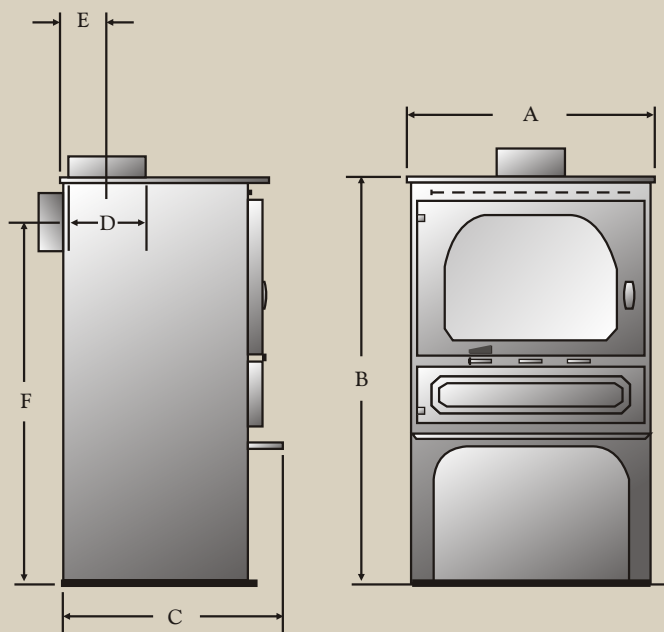

## Highlander dimensions

Model	5	7	8	8 double fronted	10
<b>A</b>	425	520	605	605	690
<b>B</b>	830	920	900	630	900
<b>C</b>	385	392	375	450	375
<b>D</b>	145	170	170	170	170
<b>E</b>	105	118	118	210	118
<b>F</b>	710	800	780		780

measurements in millimetres

## Flue Pipe

The Highlander 7, 8 and 10 require a 6" DIA 150mm Flue.  
The Highlander 3 and 5 has a 5" DIA 125mm Flue outlet.

# Dunsley Highlander 16

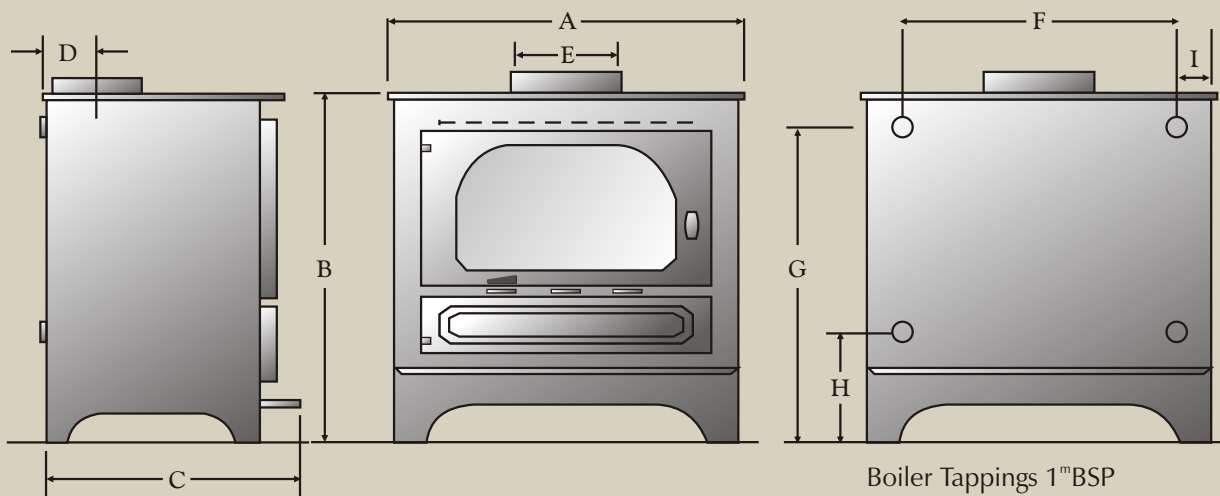

Boiler Tappings 1<sup>st</sup>BSP

## Highlander 16

<b>A</b>	690
<b>B</b>	765
<b>C</b>	485
<b>D</b>	118
<b>E (Internal Ø)</b>	160
<b>F</b>	485
<b>G</b>	715
<b>H</b>	250
<b>I</b>	85

measurements in millimetres

Note - the Highlander-16 takes 150mm flue

# Dunsley Highlander Accessories

The ash container and fuel carrier are also suitable for most room heaters, stoves and open fires  
measurements in millimetres

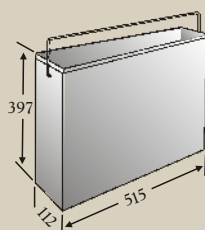

**Multi-Fuel Ash Container**  
Part No. 01414

The Highlander ash shovel slides into the ash container to avoid possible spillage of ash when carrying through your residence.

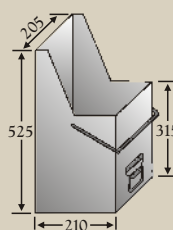

**Fuel Carrier**  
Part No. 01429

The nose fits easily through the door of the Highlander to re-fuel.

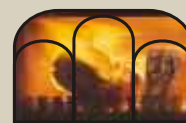

**Decorative Window Trim**  
in position on stove window, can be fitted or removed easily

**Stove Canopy with Top Flue Outlet**

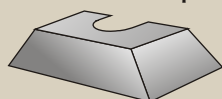

**Stove Canopy with rear flue Outlet**

If it is intended to fit the canopy onto the stove add 135mm to the height.

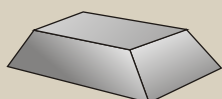

**Air vent**

HETAS approved thru-the-wall air vent for stoves over 5kW output. The internal grill is white with the external in terracotta - maximum length of 358mm



Highlander 3



Highlander 5



Highlander Enviroburn 5



Highlander 7



Highlander 8 SD



Highlander 8 & 10



Highlander 10 SD



Highlander 8 DF



Highlander 5 & 7 LS



Highlander 8 & 10 LS



Highlander 16



Yorkshire Stove

See the full range at the Dunsley website:  
[www.dunsleyheat.co.uk](http://www.dunsleyheat.co.uk)



*Dunsley Heat*

It's quality that counts

Dunsley has been Designing and Manufacturing superior solid fuel heating equipment for nearly 60 years.  
Dunsley Heat Limited, Bridge Mills, Huddersfield Road, Holmfirth, Huddersfield HD9 3TW, England  
Tel: 01484 682635 Fax: 01484 688428 email: [sales@dunsleyheat.co.uk](mailto:sales@dunsleyheat.co.uk)  
Web Site: [www.dunsleyheat.co.uk](http://www.dunsleyheat.co.uk)

Dunsley are continually reviewing products and may make alterations without notice



All Dunsley stoves  
are manufactured  
in Great Britain